

SNIPE CLASS INTERNATIONAL RACING ASSOCIATION

European Junior Snipe Championship Junior European Championship Trophy

26th – 30th July 2023

Marina Coruña Sailing Club

SAILING INSTRUCTIONS

Breach of the instructions marked [NP] shall not be grounds for protests between boats. This changes rule 60.1(a).

The penalty for breaking sailing instructions marked [SP] shall be fixed, without a hearing, and imposed by the race committee or technical committee on the most recently completed race, applied as stated in rule 44.3 RRS or a [DP] applied by the protest committee with a hearing. (This changes rules 63.1 and A5 RRS).

1 RULES

1.1 The regatta will be governed by the 'rules' as defined in the current World Sailing Racing Rules of Sailing and those listed in paragraph 1 of the Notice of Race.

2 CHANGES TO THE SAILING INSTRUCTIONS

Any change to the Sailing Instructions shall be posted on the VONB at least 2 hours before the scheduled starting time of the first race of the day it takes effect, except that any change to the racing schedule shall be posted before 8 p.m. on the day before it takes effect.

3 COMMUNICATION WITH COMPETITORS

3.1 Notices to competitors will be posted on the Virtual Official Notice Board (VONB), regatta website:

<https://escora.rfgvela.es/toa/2023-snipe-jr-european-championship>

3.2 The Race Committee may create a WhatsApp group for information purposes with the participants and support persons (QR CODE PUBLISHED ON THE VONB).

3.3 The race office is located next to the reception office of Marina Coruña.

3.4 At sea, the race committee will be transmitting and listening on VHF channel 71.

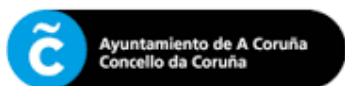

4 CODE OF CONDUCT

[DP] All competitors and support persons shall comply with any reasonable request of a race officer.

5 SIGNALS MADE ASHORE

5.1 Signals made ashore will be given at the main signal mast located in the main area of the course.

5.2 In addition to the provisions of 'Race Signals' of the RRS, the following signals will be used:

(a) When the flag 'AP' is displayed ashore, the words '1 minute' in the Race Signal AP rule are replaced by 'not less than 45 minutes'. This changes the Race Signal AP signal.

(b) [NP][DP] ICS flag 'D' hoisted with a phonic signal means: 'Competitors may proceed to the racing area'. The next warning signal shall not be given earlier than 45 minutes after this signal is hoisted or the scheduled time, whichever is later. No boat may leave the shore facilities before this signal is made, except with the express permission of the Race Committee (RC).

6 FORMAT

6.1 The race will be sailed in a fleet.

7 SCHEDULE

7.1 The schedule of races is as follows:

DATE	TIME	EVENT
Wednesday, 26 th July 2023	10:00 to 14:00 hrs 15:00 to 19:00 hrs	Inspections of the equipment; Registration
Thursday, 27 th July 2023	12:30 hrs	Skippers meeting , trainers or team
	14:00 hrs.	Warning first race of the day
Friday, 28 th July 2023	13:00 hrs	Warning first race of the day
Saturday ,29 th July 2023	13:00 hrs	Warning first race of the day
Sunday, 30 th July	12:00 hrs	Warning first race of the day
	17:00 hrs	Price Giving

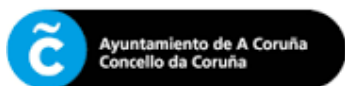

7.2 A total of 8 races are scheduled, two per day. One race may be brought forward in the schedule.

7.3 To warn boats that a race or sequence of races will start shortly, the orange flag on the starting line will be hoisted with a sound for at least five minutes before the warning signal is given.

7.4 On the last day no warning signal will be given after 16:00.

8 CLASS FLAGS

The class flag will be the class logo on a white background.

9 RACING AREA

9.1 The Racing area is published on the Annex 2.

9.2 The racing area is defined as the area of a polygon whose edge exceeds by 100 metres the shortest theoretical course that could be raced by a boat in a race.

9.3 The starting area is defined as the rectangle covering an area of 75 metres to windward and leeward of the starting line and 100 metres outwards from each end.

9.4 The finish area is defined as the rectangle covering an area 50 metres to windward and leeward of the finishing line and 50 metres outwards from each end.

10 COURSES

10.1 The diagrams in Annex 1 show the routes, the order in which the marks are to be passed and the side on which each mark is to be left.

10.2 The gate(s) may be replaced by a single mark, in which case the mark shall be left on the port side.

11 MARKS

11.1 The marks will be inflatable and their colours are shown on the following table.

Course marks	Change of course mark	Starting line marks	Finish line marks
Inflatable YELLOW	Inflatable RED	RC flag staff boat and RC staff boat or YELLOW mark	RC boat with BLUE flag and long cylindrical YELLOW mark

11.2 A Race Committee boat signaling the change of a leg of the course is a mark as provided for in Sailing Instruction 13.3.

12 THE STARTING LINE

12.1 The Starting Line will be determined between the masts at the starting marks which will fly an orange flag.

12.2 No boat shall start later than four minutes after her starting signal, and if she does so, she will be scored without a hearing as DNS. This changes RRS rules A.4, A5.1 and A5.2.

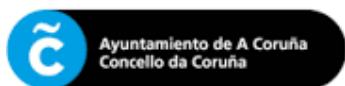

13 CHANGE OF THE NEXT LEG OF THE COURSE

13.1 The sail numbers of boats identified as UFD or BFD may be displayed on the Race Committee starting boat after all starts have been made and the first boat of the last fleet/group to start has rounded mark No. 1..

Except at a gate, boats shall pass between the race committee boat signalling the change of course and the nearby mark, leaving the mark to port and the race committee boat to starboard.

14 THE FINISH INE

The finishing line shall be defined between the mast at the finishing boat with a BLUE flag and the long cylindrical mark (yellow) for the W2, O2 and T2 courses or mark No. 1 on W, O and T courses.

15 LIMIT TIMES AND TARGET TIMES

The time limits and target times are as follows

CLASS	LIMITED TIME BUOY 1	INTENDED DURATION	LIMITED TIME FOR THE 1ST
SNIPE	25 minutes	45 minutes	75 minutes

15.1 If no boat has passed Mark 1 within the time limit for Mark 1, the race shall be abandoned.

15.2 The intended duration is only an estimate, a failure to meet the intended time will not be grounds for redress. This amends rule 62.1(a).

Boats that do not finish within 15 minutes after the first boat sails the course and finishes will be scored 'DNF' without a hearing. This changes rules 35, A4, A5.1.

16 REQUEST FOR HEARINGS

16.1 Hearing request forms are available at the regatta office. Protests and requests for redress or reopening shall be filed there within the appropriate time limit.

16.2 The protest time limit is 60 minutes after the last boat has finished the last race of the day or the race committee has signalled that there are no more races that day, whichever is later.

The resulting time will be posted on the Official Notice Board.

16.3 Notices informing the parties involved in the protests of the scheduled order of hearings and their time shall be posted on the VONB as soon as possible and no later than 30 minutes after the end of the protest time limit.

16.4 the list of boats penalized under rule 42 in accordance with RRS Appendix P and those penalized under RRS A5.1 shall be displayed at the VONB.

Appendix P of the RRS, as well as those scored under RRS A5.1. Failure to post these lists shall not be grounds for requesting redress. This changes rule 62.1(a).

16.5 The race or protest committee may protest a boat for breaking a rule in the notice of race or sailing instructions marked [SP] when it believes the fixed penalty is inappropriate. A boat that has



been penalized with an [SP] may not be protested for the same incident by another boat nor may any other boat seek redress for this action by the race committee. This changes RRV 60.1

16.6 Protest hearings will be held in the Protest Committee's offices, located next to the regatta office.

17 SCORING

17.1 There are 8 races scheduled, three of which must be completed for the European Junior Snipe Championship to be valid.

17.2 it will applied the Apendice A and the Sistema de Puntuación Baja descrito en la regla A4, además:

- (a) When 4 or fewer valid races have been completed, the total score for each boat shall be the sum of all her points..
- (b) When 5 or more valid races have been completed, the total score of each boat shall be the sum of all her points excluding her worst result.

17.3 To request a correction of an alleged error in the published results of a race, a boat shall complete a 'Results Review Form' available from the race office..

18 REGLAS DE SEGURIDAD [NP] [DP]

18.1 A boat that retires from a race or decides not to sail for the day's racing shall notify the race committee as soon as possible and in any event shall report this fact to the race office at the earliest opportunity.

18.2 [SP] In the event of an "Intelligence" or "N" flag being flown over an "H" or "A" together with the ICS flag "V" on any Committee ship, it shall mean:

“All boats shall immediately return to port”.

Any competitor failing to comply with this Sailing Instruction shall be penalised 10 points in the most recent race sailed. His score shall be no worse than a DNF.

18.3 Boats which for any reason come ashore at any point away from the Club should be notified urgently by calling one of the following telephone numbers:

PERSON OR ENTITY	TELEPHONE	VHF CHANNEL
Racing committee	649845450	VHF 71
Coordinador de Seguridad	650167455	VHF 71
Oficina de Regatas	676465305	VHF 71

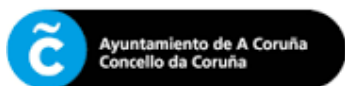

19 BOATS OF TRAINERS AND SUPPORT STAFF [NP] [DP]

19.1 All boats of coaches and support personnel must be clearly and visibly identified with the badge provided by the Organizing Body and will only dock in the places assigned by the organization..

19.2 Each trainer must declare at the time of registration which racing boats they support.

19.3 Support persons duly registered as coaches shall remain outside the areas defined in IR 9.2, 9.3 and 9.4 where boats are racing, except in an emergency or when directed by the race committee under RRS 37, from the warning signal until all boats have finished or retired, or until the race committee signals a postponement, general recall or abandonment.

20 OFFICIALS BOATS

The official boats will be identified the following way:

Race committee	White flag with CR letters
Protest committee	Flag showing "J" or "JURY"
Team inspector .	Flag showing "M"

21 BOAT LAUNCHING AREA [NP][DP]

Boats will only stay in the places officially assigned by the organization.

22 AWARDS

Trophies will be awarded in accordance with paragraph 16 of the Notice of Race. Other trophies will be published in the VONB before the start of the championship..

23 SOCIAL EVENTS

The planned Social Events will be published on the Official Notice Board (VONB).

24 DISCLAIMER OF LIABILITY

24.1 Participants take part in the race at their own risk and responsibility..

24.2 The Organizing Committee or any person or body involved in the organization of the event disclaims any liability for any loss, damage, injury or inconvenience to persons or things, whether on land or at sea, arising from participation in the events covered by this Notice of Race. Attention is made on Fundamental Rule 3, Decision to race, on RRS, part 1, stating:

"The responsibility for a boat's decision to participate in a race or to continue racing is hers alone."

At ACoruña, July 2023

ANNEX 1

Courses

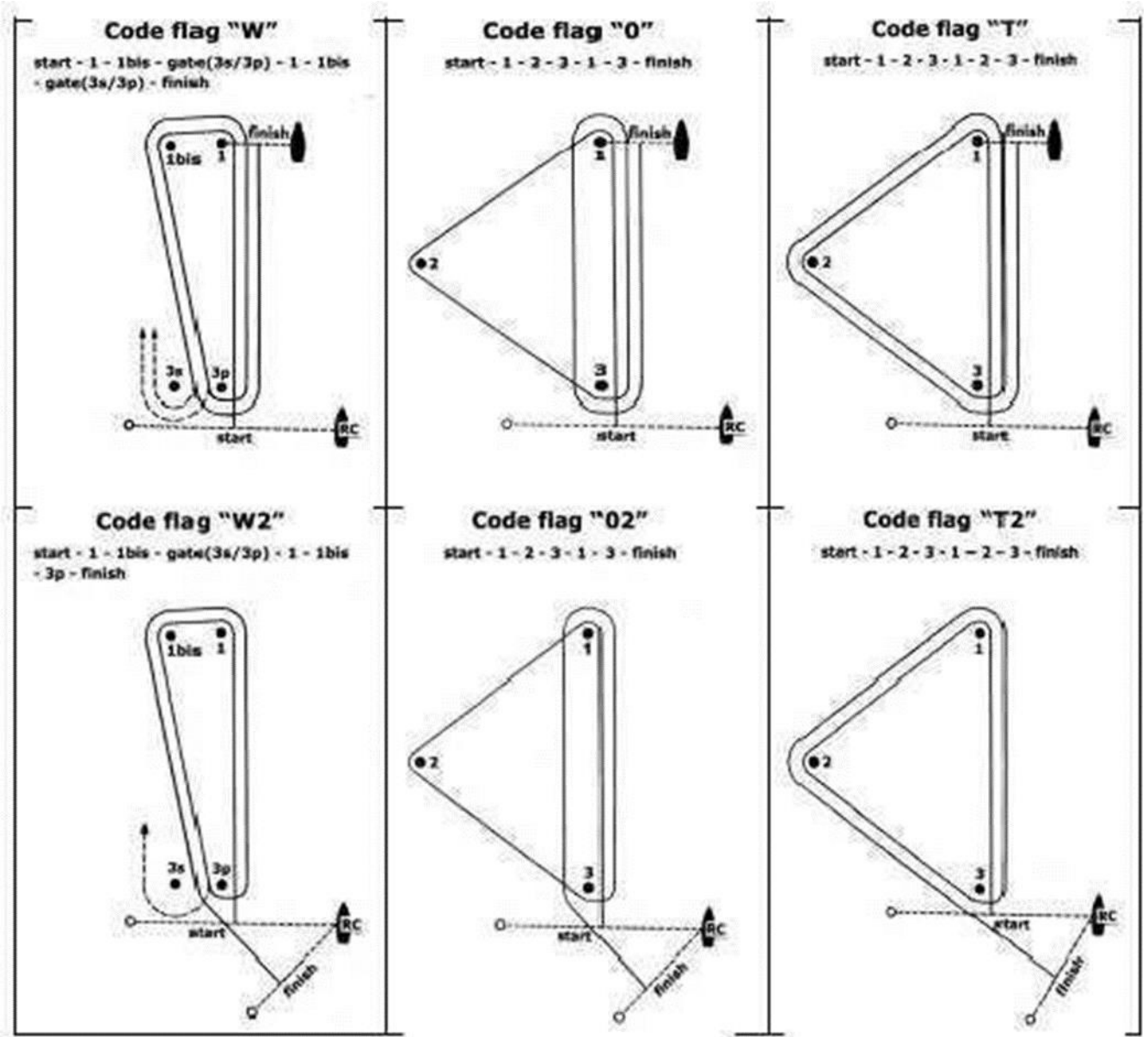



ANNEX 2

AREA DE REGATAS





ANNEX 3

EQUIPMENT INSPECTION INSTRUCTIONS [NP] [DP]

1. General

- 1.1. All boats and their equipment entered in the EUROPEAN JUNIOR SNIPE CHAMPIONSHIP may be inspected at any time and must comply with the applicable rules, including the Class Rules, these Equipment Inspection Instructions (IIE), Notice of Race (AR) as well as the Sailing Instructions (IR).
- 1.2. Competitors are reminded that, in accordance with RRV Rule 78.1, they are responsible for ensuring that their boats and equipment comply with the Class Rules and that their Measurement Certificates are valid..
- 1.3. Sails shall be certified and marked as required by the Class Rules.
- 1.4. Competitors shall present or certify the existence of a valid certificate for their boat and equipment. Certification documentation may be retained by the Equipment Inspector during the event.
- 1.5. Equipment Inspection schedules shall be published on the official website of the event.

2. . Pre-event Equipment Limitation All items of equipment subject to event limitation control shall be marked with the official markings (stamp or stickers) supplied by the organisation. If a marking becomes unclear, unsafe or is lost, this shall be reported to the TC so that the marking can be replaced, prior to the next race.

3. Modifications, Repairs and Replacement of Ships and Equipment

- 3.1. Except for the normal adjustment of fittings and equipment, modifications, repairs or replacements may not be made after the completion of the Official Event Equipment Limitation process without the approval of the Equipment Inspector. In any case, modifications, repairs or replacements requested afloat may be approved verbally, either by the Race Committee or by the Equipment Inspector on the water; but in no case prevents them from being submitted in writing on arrival ashore before the end of the protest time limit. Requests to change equipment for damage occurring during the day's races shall be submitted to the race office within the protest time limit.
- 3.2. Equipment subject to inspection shall only be replaced if:
- 3.3. Lo reemplazado fue certificado, si lo requiere las Reglas de Clase, y no altera la limitación de material.



- 3.4. Replaced equipment has been severely damaged, cannot be repaired in a reasonable time before the next regatta and the equipment inspector attests to this fact. However, equipment may not be replaced if it has been deliberately mistreated, damaged or lost by the competitor or any person connected with the competitor.
- 3.5. . Unless approved in writing by the Equipment Inspector (EI), repairs or modifications shall not be carried out in the equipment inspection areas.
- 3.6. . Boats shall not be moved from their assigned places during the regatta except with the written permission of the Equipment Inspector.
- 3.7. Forms for requesting approval of modifications, repairs or replacements shall be available from the Race Office.
4. Inspection and equipment during the event
 - 4.1. When instructed by an Equipment Inspector, a boat shall proceed as requested to a designated area for inspection. A notice may be posted on the Official Notice Board identifying the boats that have been selected for inspection and the time when they will report to the Equipment Inspection Area. A boat representative will be present during the whole inspection of equipment. A boat representative is a crew member, a team leader or a designated delegate.
 - 4.2. All boats selected for equipment survey shall be presented for inspection with complete equipment, including sails, personal flotation devices. Personal flotation devices shall comply with the Class Rules (ISO 12402-5, L-50, USCG Type III, AUS PFD 1 or EN 393 or equivalent).
 - 4.3. Boats and equipment shall be presented for equipment inspection in a dry, clean and unsalted condition. Any item not in a condition to the satisfaction of the equipment inspector may be retained by the equipment inspector until it is found to be in this condition. The notified crew shall not leave the equipment inspection area without the permission of the equipment inspector.
 - 4.4. A visual check can be made on the water of:
 - 4.4.1. Compulsory hardware and equipment to be used in racing
 - 4.4.2. Control of equipment limitation marking
 - 4.4.3. Measures hands
 - 4.5. If a measurement is varied from that prescribed by the class rules, repaired, or replaced without prior approval, the Technical Committee shall communicate directly to the Results Officer (Race Committee) the penalties applied in accordance with Annex 5. [DP][NP][SP] Measurement Protests and Standard Penalties (Annex 4)



5. The Technical Committee shall protest those boats found to be deviating from the Class Rules, Sailing Instructions or Equipment Inspection Instructions, which form part of the IR and are not included in the Annex.



ANNEX 4

[SP] STANDARD PENALTIES FOR BREACHES OF SNIPE CLASS RULES OR FAILURE TO COMPLY WITH SAFETY RULES – SCORING PENALTY (PERCENTAGE ON

Penalties described in this annex will consist on a scoring penalties. The score that that would have been received without the penalty, made worse by a number of points obtained by applying the percentage below on the score for DNF, rounded to the nearest whole number (0.5 rounded upward). However, the penalty shall not cause the boat's score to be worse than the score for Did Not Finish.

- NO SHACKLE OR CARABINER ON THE END OF THE DAGGERBOARD LINE: 20%
- DAGGERBOARD SAFETY LINE SHACKLE OR CARABINER NOT ATTACHED DIRECTLY TO THE DAGGERBOARD TRUNK: 40%
- DAGGERBOARD SAFETY LINE HOLDING A LENGTH BEYOND THE KNOT: 20%
- LACK OF A PROPER DAGGERBOARD RETENTION SYSTEM: 20%
- LACK OR NON-HOMOLOGATED PERSONAL FLOTATION AID: 50%
- LACK OF ANY OF THE FOLLOWING ITEMS: TOWING ROPE, PADDLE OR RUDDER RETAINER: 20%
- JIB ATTACHMENT TO FORESTAY FITTING NOT COMPLYING WITH CLASS RULE C.10.6(d): 10%
- DAGGERBOARD SAFETY LINE LONGER THAN PERMITTED: 50%
- USE OF ANY EQUIPMENT WITHOUT CHAMPIONSHIP MARKING, BUT COMPLYING WITH CLASS RULES: 20%
- USE OF ANY SAIL WITHOUT OFFICIAL MEASUREMENT STAMP: 30%
- WRONG SAIL NUMBERS, UNEVEN COLOUR OR SHAPE: 10%
- WRONG BOAT WEIGHT, RIGHT CERTIFICATE: 40%
- BOAT BALLAST DIFFERING FROM WHAT IS INDICATED BY CERTIFICATE: 40%
- MAST, BOOM OR WHISKER POLE INCORRECT LENGTH OR LACKING STOPPERS: 30%
- LACK OF UPPER LIMIT MARK ON MAST OR OUTER POINT MARK, BUT HOLDING STOPPERS: 10%
- MAST UPPER LIMIT MARK, BOOM OUTER POINT MARK OR DAGGERBOARD MARK TOO DETERIORATED: 5%
- MAST, BOOM OR DAGGERBOARD LACKING BANDS: 15%
- DAGGERBOARD BAND AT WRONG POSITION: 30%
- USE OF ANY EQUIPMENT NOT COMPLYING WITH CLASS RULES, HOLDING CHAMPIONSHIP MARKING: 40%
- THE TOP OF THE DAGGERBOARD RETRACTED POSITION LIMIT MARK SHALL NOT BE ABOVE THE TOP SURFACE OF THE DECK AT THE CENTRELINE OF THE BOAT – C.8,4 (a)(4): 30%